

数字集成电路原理

课堂讨论4

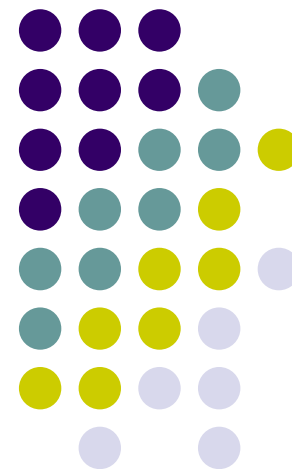

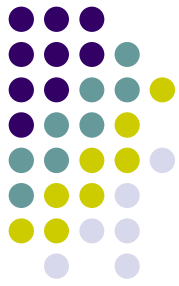

讨论题

1、比较全加器的两种实现方案。

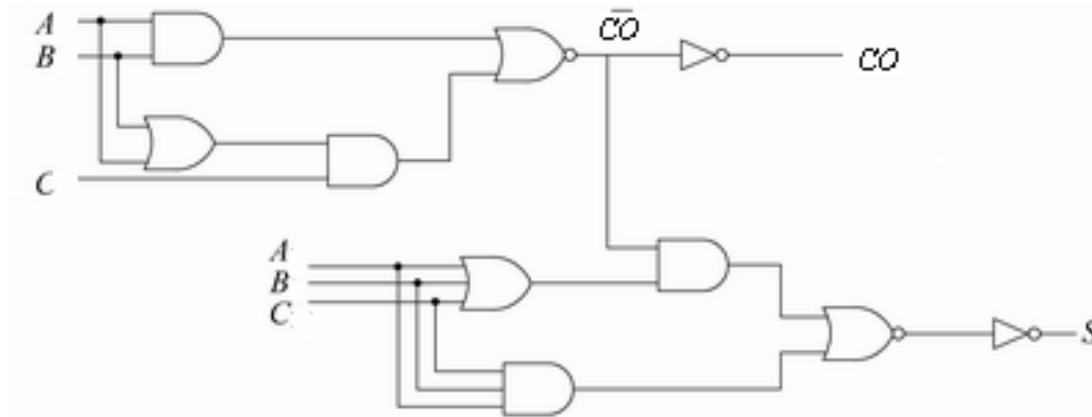
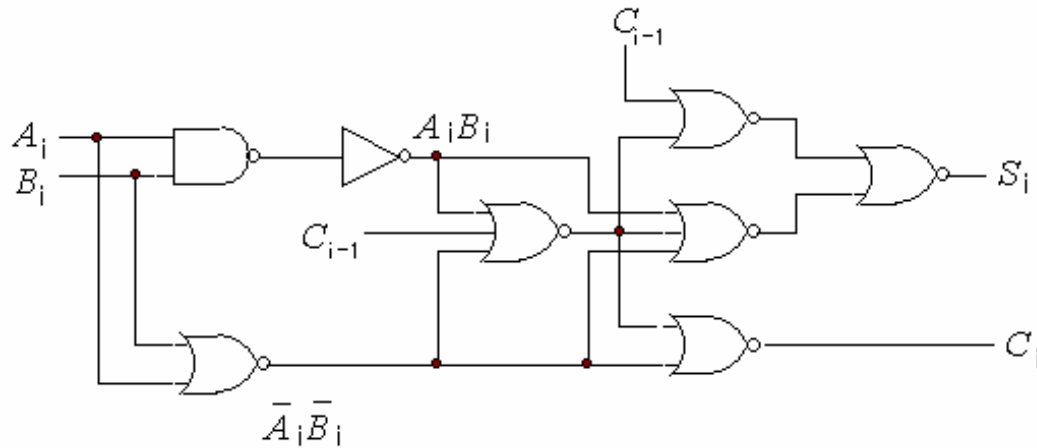



讨论题

- 2、 给出书中表**5.1—4** 单输入编码的**4—2** 编码器的电路级实现方案。



3、分析4位同步二进制可置数可逆计数器

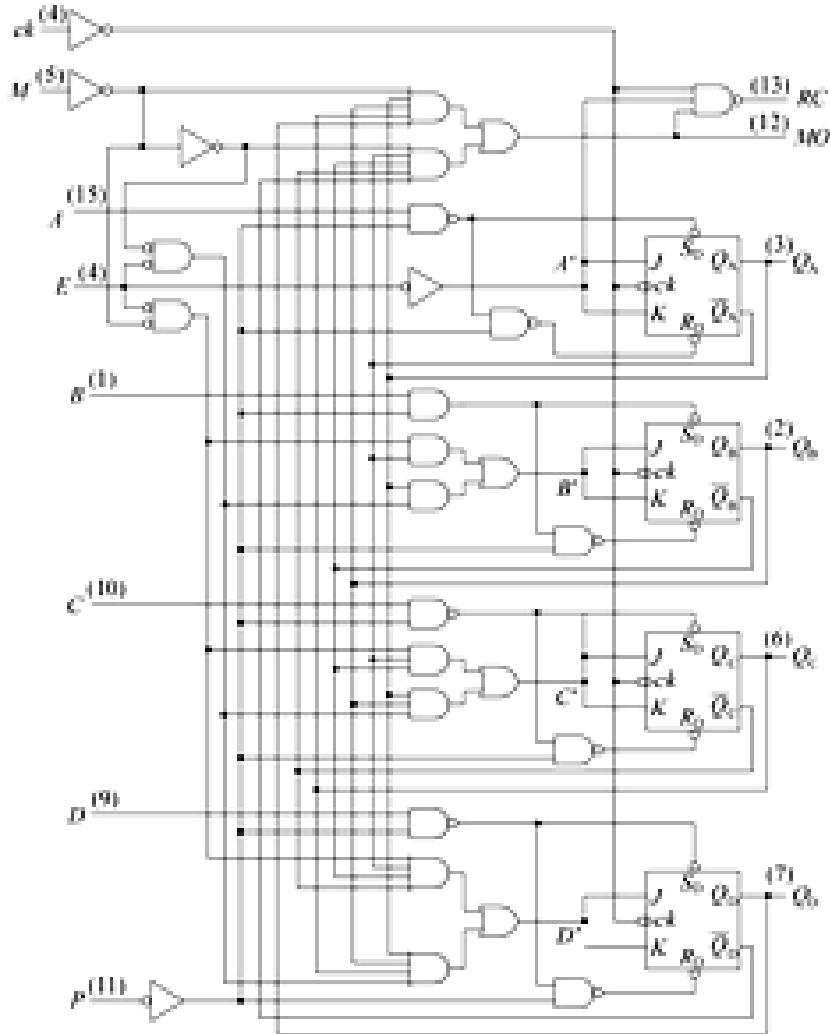

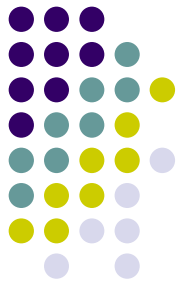

4、分析这个电路的工作原理以及对时钟信号和D信号的时序要求。

